

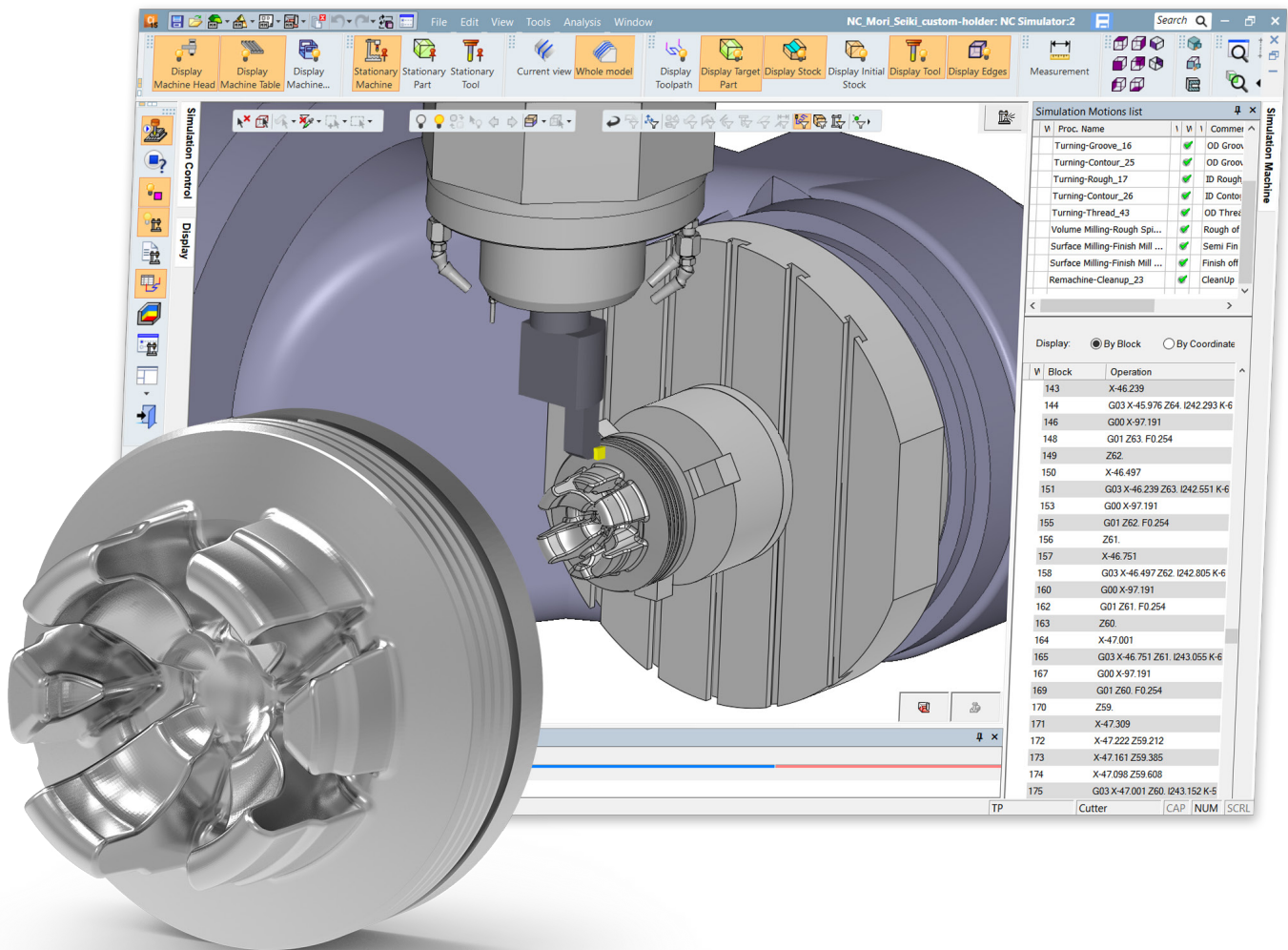

Streamline your Mill/Turn process



Cimatron Mill/Turn application enables faster machining and better surface quality for tool makers who want to use the familiar and safe environment of Cimatron to program their Mill/Turn and Turning parts.

Turning with Cimatron supports full functionality for roughing, high-performance roughing (using VoluTurn), contouring, threading, grooving, tapping and boring. The application is fully integrated within the Cimatron CAM environment allowing easy programming, machine simulation and post processing of the entire NC process – Milling, Drilling and Turning.

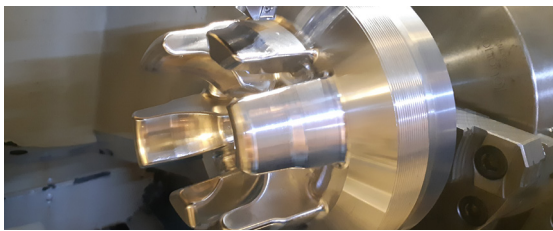

Cut Your Machining Time by Half and Get Even Better Finish Surface Quality

Machine with a Mill/Turn Process

04:42:00 hours



Machine with a Milling only Process

11:02:50 hours

Key Features:

Turning capabilities to support more machines

- Better utilize your Mill/Turn and Turning machines
- Combine turning with advanced 5-Axis milling to get the most out of your machine

Easy creation of turning cutters

- Easily create cutters using key dimensions
- Use a wide variety of predefined common tool shapes
- User-defined form tools and holders

One stock model updated for the entire process

- Revolved stock by contour, bounded cylinder and more
- The stock model is fully updated throughout the entire process, both for turning and milling procedures

Powerful design capabilities for contour creation

- Spun silhouette of the turning body
- All other contour creation options from Cimatron CAD

Customizable toolpath creation

- Turning from all directions: outside diameter, inside diameter, front facing and back facing
- Full control over technology: cutting direction, tool orientation, entry and retract mode and more

Turning Strategies

- **Rough** strategies: turn, pattern shift, plunge etc.
- **VoluTurn** for high-speed roughing using round insert
- **Contour** for finishing operations
- **Drilling, Grooving and Threading**

Machine with confidence using Cimatron's machine simulation for the entire process - milling, drilling and turning.

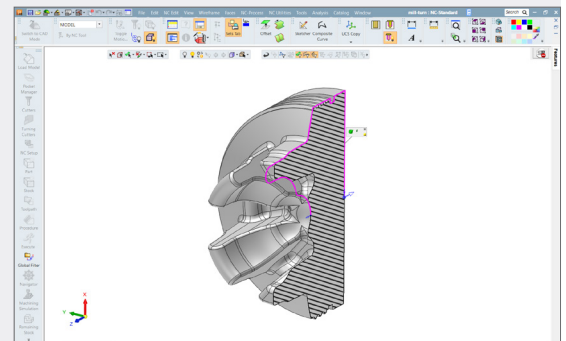
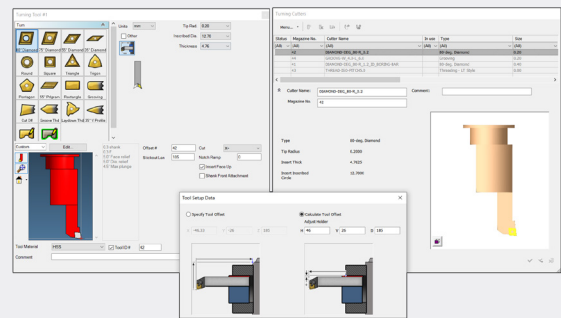

3D Systems provides comprehensive 3D products and services, including 3D printers, print materials, on-demand parts services and digital design tools. Its ecosystem supports advanced applications from the product design shop to the factory floor to the operating room. As the originator of 3D printing and a shaper of future 3D solutions, 3D Systems has spent its 30 year history enabling professionals and companies to optimize their designs, transform their workflows, bring innovative products to market and drive new business models. Specifications subject to change without notice. 3D Systems, the 3D Systems logo, Cimatron are trademarks of 3D Systems, Inc. All other trademarks are the property of their respective owners.

Introducing Cimatron 15

Cimatron® 15 introduces hundreds of new and enhanced capabilities, aimed to enable toolmakers deliver high quality tools faster and easier, while reducing costs. New, enhanced and automated NC programming capabilities enable manufacturers to shorten programming and machining time. A new Mill/Turn application was added to the Cimatron NC environment enabling customers to program Mill/Turn and Turning machines within the same familiar environment. New and enhanced tool design capabilities enable mold makers to design faster, improve manufacturing quality and get optimal design of Molds, using automated cooling design capabilities and new analysis tools.

Version Highlights:

New Mill/Turn Application

New Mill/Turn capabilities were added to Cimatron for faster machining and better surface quality for tool makers that want to use the familiar and safe environment of Cimatron to program their Mill/Turn and Turning machines. Turning with Cimatron supports full functionality for roughing, high-performance roughing (using VoluTurn), contouring, threading, center drilling, tapping and boring.

The application is fully integrated within the Cimatron CAM environment allowing easy programming, machine simulation and post processing of the entire NC process – Milling, Drilling and Turning.

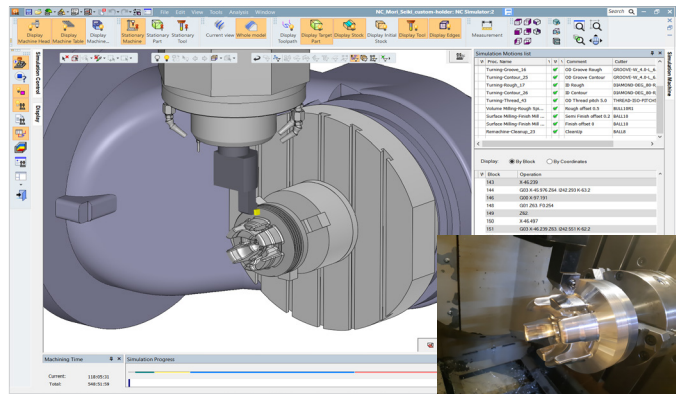

A new Mill/Turn application is fully integrated within the Cimatron CAM environment

New and Enhanced 5-Axis Milling Capabilities

- Automated 5-Axis Roughing – Optimized Roughing for multi-directions can now be programmed and calculated entirely and automatically by the system for maximum material removal in minimal machining time from optimal selected directions. Users can now let the system calculate complex part roughing for them.

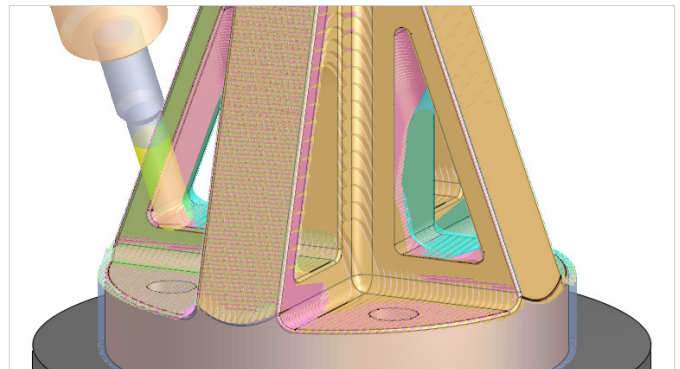

A Fixture rough cut, using automatic Rough 3 +2 axis set of operations. The stock is colored by the orientation. The directions are defined automatically by the system

New and Enhanced 5-Axis Milling Capabilities - cont.

- Guided Multi-Axis Cleanup – in a click of a button, the system calculates optimized multi-directions cleanup motions, taking into account the tool and holder shape to protect from potential collisions.
- Advanced Finish with the new Geodesic Technology – A new high quality toolpath calculates an even 3D step over on complex parts. It includes support for guide curves, undercut and consider holder to prevent collisions. Users can use it for 3-axis, 4-axis and 5-axis toolpath typically used for parts that require high quality surface finish such as mold and die cores and/or cases where a continuous toolpath start-to-end without re-entries is required.
- New 5-Axis Automatic Deburring - Automatically program deburring operations by selecting geometry, surfaces or an entire model. The toolpath considers the machine axis limits and holder to create a collision-free toolpath. Users can use it for 3-axis, 4-axis and 5-axis toolpath on jig and fixtures as an example.

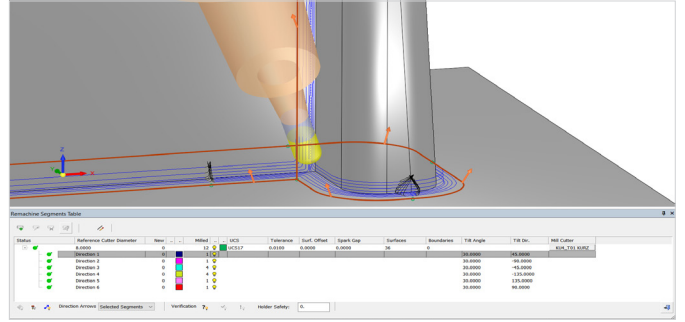

Zoom-in picture of a cleanup corner, machined in an inclined 3 + 2 axis orientation. The orientation was calculated automatically by the system, as part of the Guided Cleanup Auto Tilt function.

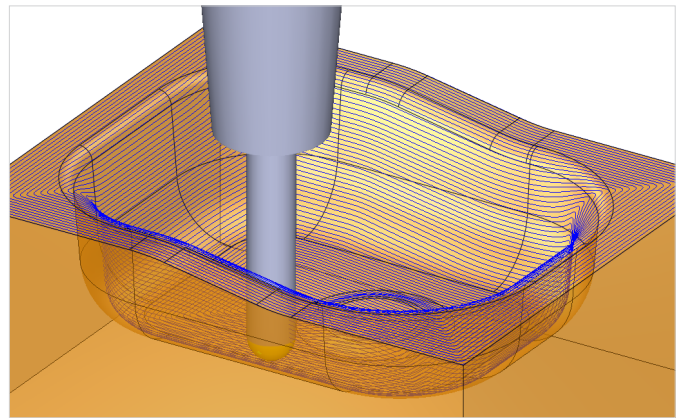

A start-to-end 3D Step Geodesic 3-axis toolpath on a steel cavity, with no re-entries, to achieve best surface quality without approach retract marks.

Plate Machining Automation and Enhancements

Plate Machining Enhancements – While plate machining considered to be a rather simple 2.5 Axis set of operation, it consists of many procedures with many programming parameters that might require a long programming time. New and enhanced capabilities were added to version 15, in order to automate & shorten the programming process and achieve safe and efficient toolpath.

This includes:

- Manufacturing Feature Recognition
- Pocket, Slot and Hole Manager
- Pocket Template
- Automated Drill including Drilling Sequences
- Rough Pocket
- Corner Plunging - New
- Collision Free Profile
- Helical Profile

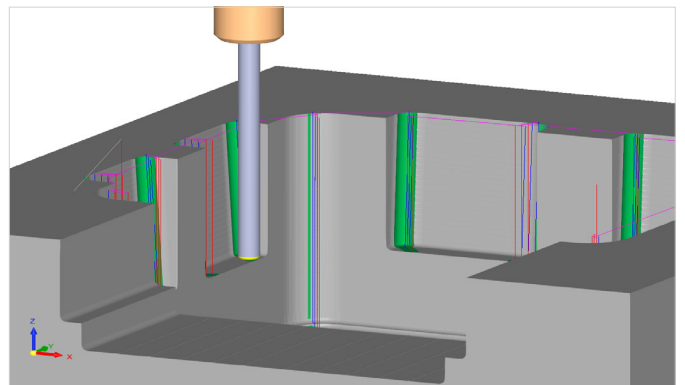

An efficient re-rouging at corners is done with the new "Corner Plunging" procedure, where the stock is removed by down cutting operations, including an option for forward steps.

Fast Machining with Circle Segment Cutters and Enhanced AFC

- Enhanced Automatic Feed Control (AFC) in Rough – enables to optimize stock to be removed by automatically controlling the feed rate, resulting in smoother and safer motions, faster Roughing machining time, less drastic changes on the machine spindle and axes and longer tool life.
- Circle Segment Cutters in Finish – Barrel, lens, oval and now also 3-radii segments cutting tools can be utilized by Cimatron toolpath strategies. Using any of these cutters will shorten the machining time for a given scallop while achieving even better surface quality.
- All-Rounded Toolpath in Rough, Finish and Cleanup Operations – Users can now create rounded motions over the entire toolpath on corners and connections resulting in Smoother machine motion, less vibrations and longer tool life.

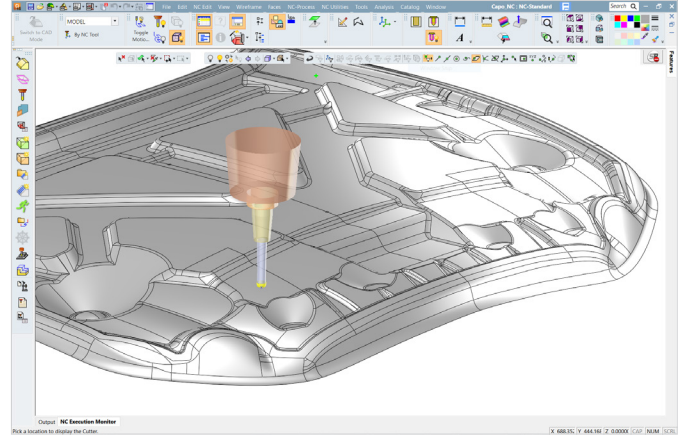

Finishing this car engine hood die tool using a Circle Segment cutter diameter 20mm, machining time can be reduced by 10% from 132 hours down to 119 hours compared to using a ball tool diameter

Other New and Enhanced NC for Tooling Capabilities

- Shank and Holder Control and Predictability – The insight and control over the shank and holder's safety and calculation parameters were greatly improved with a new dynamic dialog. Users can now control which elements will be considered/ ignored using which technology and in which level of accuracy. The ability to better control and understand the influence and behavior of the different parameters will enable to generate the desired toolpath.
- New Utility Procedure – A new procedure in the process manager allows users to define and save commands and comments that will not generate toolpath, such as 'open door', 'move to' etc'. These will be saved in the process manager and processed by the post-processor to the G-code.
- Additional Coolant Options – Users can now define and control additional coolant types to be used on the CNC machine. This includes the option to select multiple coolant types.
- Finish by 4 Limit Angles – Users now have better control on the angles range for the vertical areas and the horizontal areas. This can be utilized in cases where users want to exclude a complete horizontal planar area or when utilizing circle segment cutters.
- 3D Cutter Compensation in Finish – In cases where the part requires high accuracy dimensions, a common shop floor process was to run several cycles of milling and programming until the desired result was achieved. This used to be a long programming process that occupied the NC programmer. The new 3D Cutter Compensation functionality allows the shop floor operator to modify the cutter compensation parameter on the machine controller without the need to get a new program from the NC programmer.

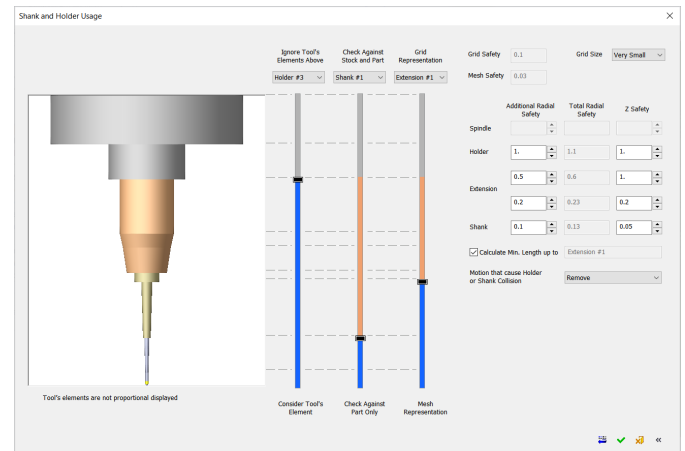

A new shank and holder dialog enables better user control and full transparent information over the different cutter assembly components including shank, extension, and holder stages, for considering or ignoring, for safety and for minimal clear length with complete feedback interactively

Cooling Channel Design and Manufacturing

The Cooling application was dramatically improved in this version, while we continue to support a mixed/hybrid manufacturing environments with subtractive and additive solution. A mix of both traditional and conformal cooling capabilities enables efficient design, resulting in shorter injection cycle time and better parts quality due to reduced warpage.

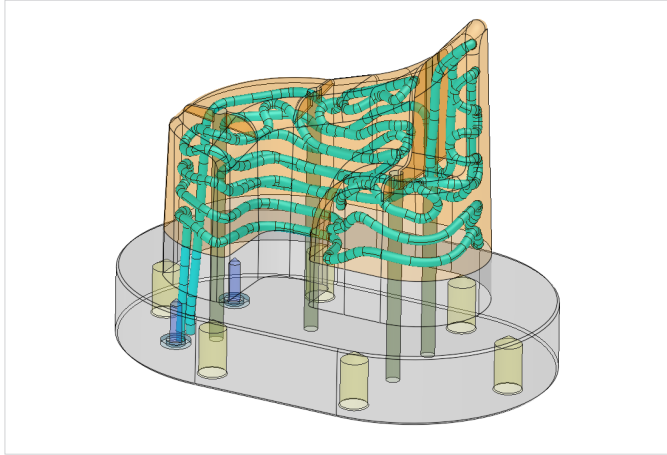

Automatically generated Conformal Cooling channel

Conformal Cooling Design

- A New Conformal Cooling Application – The advantages of using conformal cooling are clear in relevant cases but the design of conformal cooling channels used to required expertise and know-how. With the new release, any mold maker will be able to generate a conformal cooling channels with fast and easy to use automated tools. Hours of design work can turn into minutes. Users can control and modify the automated results, or create their own channel design much easier.

- New Analysis Tools for Conformal Cooling:
 - Overhang analysis – Ensure no internal areas within the cooling channels will fail during printing.
 - Distance analysis and optimization – Identify areas where the channels may be too close or too far to\from the walls of the insert and adjust them automatically.

Conformal Cooling Standalone Seat for Non-Cimatron Users

A standalone seat for conformal cooling design is offered to mold makers using other software for mold design or conformal for cooling printing bureaus, with all the tools necessary to complete the design.

Traditional Cooling Design

- New Cooling Channels Analysis – Extremely fast analysis for a quick glance at cooling efficiency based on the distance between the cooled faces and cooling channels.
- Cooling Labeling – Easily add labels next to each channel, save time and avoid mistakes.

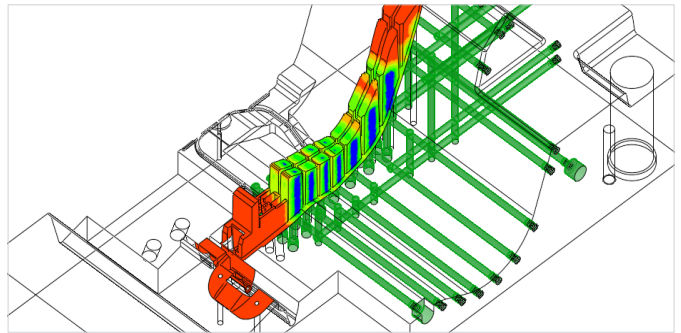

A color map of distances between part faces and cooling channels

Additional Mold Design Capabilities

- Mold Correction - Warpage Compensation - A new functionality enables getting the actual molded part model (either by molding the part and scanning it, or from a simulation system), and change the design of the mold to compensate for warpage so that the final molded part fits the required dimensions and tolerances.
- New Direction Analysis - The system can now provide a fast analysis to automatically find the best orientation for the mold's opening direction (a crucial initial step of mold design) with the least amount of under-cuts. This is especially useful for parts with an ambiguous or hard to find parting line (for example – automotive pipes).

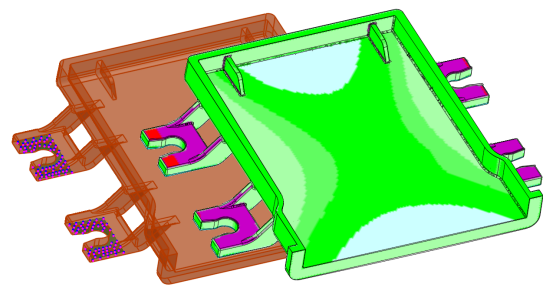

Deviation between molded part and part model recognized and compensated for warpage



Find out more at: <https://www.3dsystems.com/software/cimatron>

3D Systems provides comprehensive 3D products and services, including 3D printers, print materials, on-demand parts services and digital design tools. Its ecosystem supports advanced applications from the product design shop to the factory floor to the operating room. As the originator of 3D printing and a shaper of future 3D solutions, 3D Systems has spent its 30 year history enabling professionals and companies to optimize their designs, transform their workflows, bring innovative products to market and drive new business models. Specifications subject to change without notice. 3D Systems and the 3D Systems Logo are trademarks of 3D Systems, Inc. All other trademarks are the property of their respective owners.